

UNIVERSAL PARTS MOTORS

MFG: General Electric MODEL: 5KCP39GFT475AS MFG: Emerson MODEL: K55HXPZG-5379
 H. P. 1/5 RPM 825 SPEEDS 1 VOLTS 208-230 PH 1 HZ 60 CAP 5/370 @ 230V & 7.5/370 @ 208V
 F. L. AMPS 1.3 L. R. MPS - ROTATION Rev (OSE) FRAME 48 THERMALLY PROTECTED Yes WIND. CLASS B
 SHAFT 1/2" X 3.75" FLAT 3.25" MOTOR TYPE PSC STACK 1.375" BEARING Slv OIL See back of Instr
 TORQUE: HI 24 OZ FT (BD) @ 760 RPM @ 230 VOLT 5/370 CAP.
 MOUNTING: THRU BOLT Yes SHELL BAND Yes SHELL HOLES Yes (4) HUB RINGS No
 SHAFT POSITION All SHAFT END VENTED Closed BUTT END VENTED Closed SHELL VENTED Closed

WINDING RESISTANCE @ 23°C — OHMS

MAIN	AUX.	Temp. °C
33.1	59.9	23

Enclosure
All position totally enclosed

DESIGN NOTES: MOTOR SAME AS _____ - _____ or A DESIGN OF 51-20760-91

SPECIAL CONSIDERATIONS: ● Motor Design Capacitors are 5/370 @ 230V and 7.5/370 @ 208V, see instructions shipped with motor. Motor is shipped with instructions, GE Stuffer is SFM2442, Rheem Number 92-26177-401-00, Emerson Instructions F10667, Rheem Instructions 92-26177-228-00.

Both motors are shipped with four (4) shell hole screws, screwed into the motor shell. Print is prepared from GE's data.

PARTS DEPARTMENT

RHEEM MANUFACTURING CO.

Y-0119S000
04/15/1999

Y-0119S000
04/15/1999

General Electric's Stuffer Number Changed from R980305GE-401 to 92-26177-401-00
 Emerson's Stuffer Number Changed from R920124RT228A to 92-26177-228-00

00
00

REVISIONS

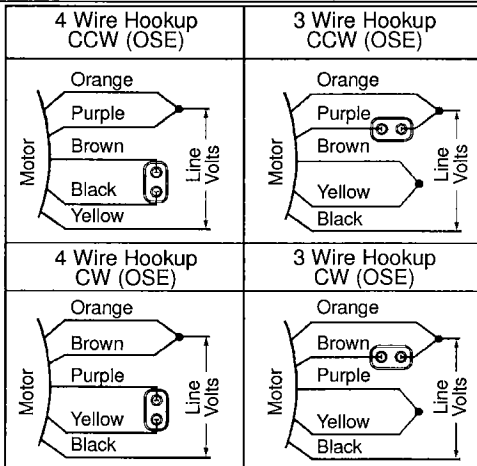

Wire Information: Lead Insulation Rating 105°C
 Thickness 4/64" Type Material PVC

Leads	Color	Wire Ga.	Length	Termination
Common	Orange	18	36"	1/4 QC Flag
Line	Black	18	36"	1/4 QC Flag
Capacitor	Brown	18	36"	1/4 QC Flag
Capacitor	Yellow	18	36"	1/4 QC Flag
Capacitor	Purple	18	36"	1/4 QC Flag
Ground	Green	18	5"	1/4 Eyelet

For Reversing Rotation See Diagram at Left.

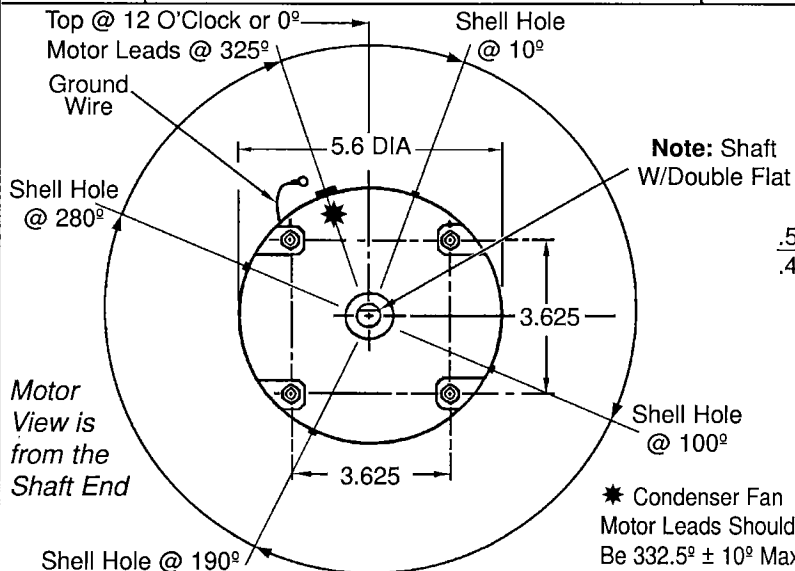

Shell Screws 8-18, p/n 63-22338-03.

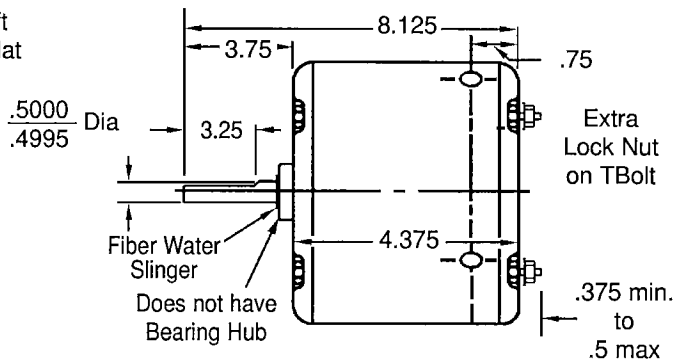

NOTE: Thru Bolts (8-32) are Reversible.

DR. BY: W. Charles | CHKD. BY: Robert Thomas | APPROVED BY: Baykal Altiner | DATE 05/10/1999 | ORIGINAL RELEASE Y-0119S000 | REV. -00

1/5 HP (208-230V), 825 RPM, 1 Speed Direct Drive Condenser Fan Motor

PART NO. **51 - 23055 - 12**